

# SMALL ENGINE

TUNE UP PARTS  
CATALOG

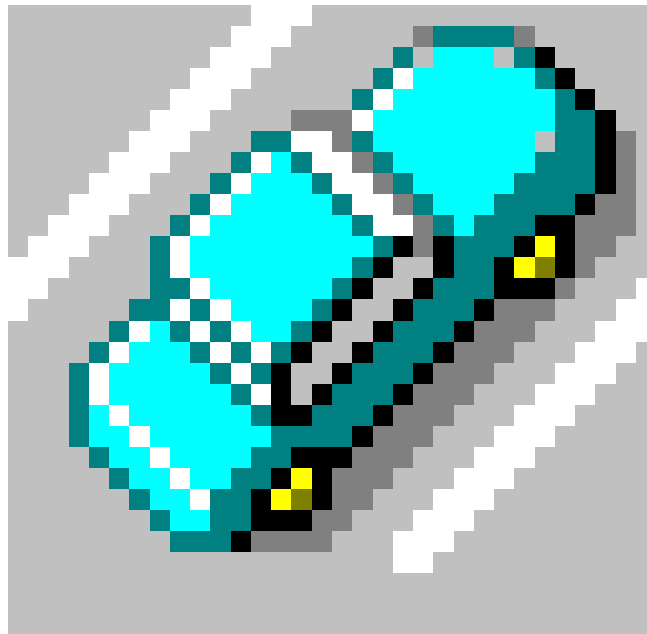

COLLECTOR'S AUTO  
SUPPLY

PHONE/FAX: 604-931-7278  
TOLL FREE: 1-888-772-7848  
COQUITLAM B.C.



**CS 1000 Contact Set**  
(10-52344W)  
**OUTBOARD ENGINE**

Champion  
Mercury  
Oliver  
**SMALL ENGINE**  
Clinton, Continental and Kohler Engines, Harley-Davidson, Remington-Union and other equipment.  
Two used on most applications



**CS 1001 SE-78 Contact Set**  
(10-56146Y)

Kiekhaefer and Titan Chain Saws, Wizard Outboards



**CS 1100 Contact Set**  
(CS 521)

Used on MJA Editions, MJB Edition A, Editions B - variable and fixed spark; MRA - MRB - MRF - Edition A.



**CS 1101 Contact Set**  
(CS 523)

Used on MJC Edition C - fixed spark; MJD - Edition A, 4B - 302 - C, W - fixed spark.



**CS 1103 Contact Assembly**  
(BK 52203)

Used on all Editions of MJH and MRJ MSA - Edition A and 4A - 308.



**CS 1200 Contact Set**  
(29667)

**SMALL ENGINE & FARM**  
Engine series: I, N, U, W, 5, 6, 6F, 6R, 6S, 8, 140,000 thru 147,000.



**CS 1202 Contact Set**  
(292021) (291371)

**SMALL ENGINE & FARM**  
Engine Series: 14, 19, 23, A, 23, B, F, P, R, 191400, 231401.

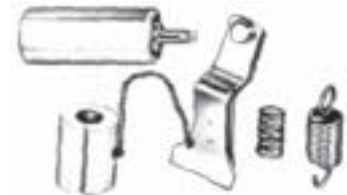

**CS 1204 Contact Set**  
(294628, X)

**SMALL ENGINE & FARM**  
Engine Series: 6B, 8B, 60100 thru 61900, 80100 thru 85902, 92900, 100202 thru 100993.



**CS 1206 Contact Set**  
(298185)

**SMALL ENGINE & FARM**  
Engines 23D, 23D-B, 23D-FB, 23D-R6, 23D-RED, 193400 to 193467, 200401 to 200466, 233401 to 23476, 243400 to 243475, 300400 to 300425



**CS 1500 Contact Set**  
(Clockwise)  
(R2437) (T2437)  
(10162437)

Used on farm FMJ Magnets.



**CS 1502 Contact Set**  
(Counter Clockwise)  
(S2437)  
(10172437)

Used on farm FMJ Magnets.



**CS 1503 Contact Set**  
**SMALL ENGINE**  
(Counter Clockwise)  
(B2437A) (X2437)  
(10222437) (10422437)

Wisconsin Engines  
Also Farm  
Used on popular FMX Harley Davidson Motorcycles



**CS 1504 Contact Set**  
(A2437A)  
(393-1100A3)  
(10412437)

**OUTBOARD ENGINE**  
Mercury '50-'69  
**SMALL ENGINE & FARM**  
(A2437A, W 2437)  
Kohler and Wisconsin Engines.  
Used on FMX and FMZ Magnets.



**CS 1506 Contact Set**  
(P-2437A)  
(10013234)  
**OUTBOARD ENGINE**

Chrysler '56-'76  
Elgin '56



**CS 1600 Contact Set**  
(353-172-R91)

Equipped with stainless steel spring and copper conductor strip. Used on J4 Magneto, and International Battery Distributors models.



**CS 1601 Contact Set**  
(353-171-R91)

Used on the H-4 Magneto.



**CS 1602 Contact Set**  
 (353-173-R91)  
 (353-200-R91)  
 Used on the F-4 and F-6 Magnetos.



**CS 1603 Contact Set**  
 (372-951-R91)  
 Used on International Battery Distributor models.

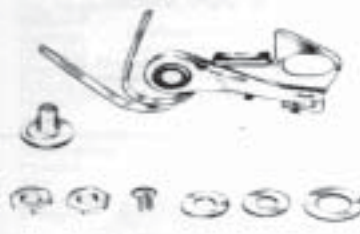

**CS 1700 Contact Set**  
 (19894, A)  
**SMALL ENGINE**  
 McCulloch Chain Saws



**CS 1703 Contact Sets**  
 (57765, A) (888072)  
 McCulloch Chain Saws



**CS 1720 Contact Set**  
 (332B-135)  
 (76098)  
**OUTBOARD ENGINE**  
 Hiawatha '60-'61  
 Elgin '60-'63  
 McCulloch '60-'69  
 Wizard '60-'62



**CS 1750 Contact Assembly**  
 (393-1504A5, A6)  
 (393-1326A3)  
**OUTBOARD ENGINE**  
 Mercury '57-'69



**CS 1800 Contact Assembly**  
 (FG 626K) (FG 2399)  
 (FG 3412) (FG 4205B)  
 (FG 4205D) (FG 3413)  
 (398-174) (398-738)  
 (134-135) (332-135)  
**OUTBOARD ENGINE**  
 Champion '50-'57  
 Corsair '48-'56  
 Firestone '47-'66  
 Hiawatha '56-'61  
 Elgin '59-'63  
 McCulloch '53-'69  
 Mercury '49-'69  
 Muncie Neptune '46-'63  
 Wizard '59-'62  
 Two used on some applications  
**SMALL ENGINES**  
 Clinton, Continental and Power Products (Tecumseh) Engines, Cushman, Lawnboy, Wright and other equipment.



**CS 1801 Contact Assembly**  
(FG 1250B) (FG 1720C)  
(FG 2310)

**SMALL ENGINE**

Clinton and Power Products (Tecumseh), Lawnboy Engines and other equipment.



**CS 1802 Contact Assembly**  
(FG 1773, B)  
(FG 3413)

**OUTBOARD ENGINE**

Elgin '59-'62  
McCulloch '58-'69

Two used

**SMALL ENGINE**

Power Products (Tecumseh) Engines  
Homelite saws and other equipment.



**CS 1804 Contact Assembly**  
(FG 2197, B) (FG 1835, B, C)  
(FG 2645) (FG 6230)

(FG 6270) (FG 2400, B)

(FG 6450) (30547)

(398-2202)

**OUTBOARD ENGINE**

Mercury '53-'69

**SMALL ENGINE**

Lauson and Power Products (Tecumseh) Engines, Remington-Mall, Wright and other equipment.



**CS 1807 Contact Assembly**  
(FG 3560)

Clinton (5735)

**SMALL ENGINE**

For Clinton Engines and other equipment.



**CS 2000 Contact Set**  
(580148)

**OUTBOARD ENGINE**

Evinrude '51-'76  
Gale '50-'63  
Johnson '51-'76

Two used

**SMALL ENGINE**

Lawnboy Engines  
Skeeter  
Ske-Horse  
Snow Cruiser



**CS 2001 Contact Set**  
(677254)

**SMALL ENGINE**

Lawnboy Engines



## COLLECTOR'S AUTO SUPPLY TUNE-UP PARTS

YOU MUST MAKE CERTAIN YOU ARE USING THE CORRECT CATALOG. FOR EXAMPLE YOU MUST USE THE AUTOLITE CATALOG IF YOUR VEHICLE USES AN AUTOLITE IGNITION SYSTEM OR THE DELCO REMY CATALOG IF THE VEHICLE HAS A DELCO REMY IGNITION SYSTEM.

THESE CATALOGS ARE AVAILABLE FREE BY REQUEST:

1. ASIAN IGNITION SYSTEMS TO EARLY 1960'S.
2. AUTOLITE IGNITION SYSTEMS TO MID 1920'S.
3. BOSCH IGNITION SYSTEMS TO MID 1950'S.
4. DELCO REMY IGNITION SYSTEMS TO MID 1920'S.
5. DUCELLIER IGNITION SYSTEMS TO MID 1950'S.
6. FORD INCLUDING HOLLEY IGNITION SYSTEMS TO 1909.
7. LUCAS IGNITION SYSTEMS TO MID 1930'S.
8. MARELLI IGNITION SYSTEMS TO 1950'S.
9. NORTHEAST & AMERICAN BOSCH DISTRIBUTOR CAPS TO 1920.
10. SEV IGNITION SYSTEMS TO MID 1930'S.
11. MAGNETO AND SMALL ENGINE TUNE-UP PARTS.
12. GENERAL

Most items are in stock. Spark plugs for all vehicles are also available.

These items are manufactured by a variety of reputable tune up part suppliers and not necessarily by the original equipment manufacturer.

Prices are in Canadian Dollars. Payment in U.S. Funds represents a discount of approximately 30%.

Dealers are invited to enquire about wholesale pricing.

# ELECTRICAL IGNITION, CHARGING, STARTING, LIGHTING, ETC.

## DISTRIBUTOR POINTS - SMALL ENGINE

BRIGGS and STRATTON Engine series: I, N, U, W, 5, 6, 6F, 6R, 6S, 8, 140,000 thru 147,000. (B&S #29667)

#CS1200 (SE-2) \$13.00

BRIGGS and STRATTON Engine series: 6B, 8B, 60100 thru 61900, 80100 thru 85902, 92900, 100202 thru 100993.(B&S # 294628, X)

#CS1204 (SE-11) \$9.00

FAIRBANKS-MORSE magnetos used on some WISCONSIN, farm, FMX, and HARLEY DAVIDSON engines. (OEM #'s:B2437A, X2437, 10222437 & 10422437)



#CS1503 (SE-57) \$8.00

FAIRBANKS-MORSE magnetos used on MERCURY 1950-1969 some KOHLER AND WISCONSIN, AND SOME FMX & FMZ magnetos. (OEM #sA2437A, 393-1100A3, 10412437, A2437A & W 2437)



#CS1504 (SE-21) \$10.00

FAIRBANKS-MORSE magnetos used on CHRYSLER outboard 1956-1976 and ELGIN outboard 1956. (OEM #'s P-2437A & 10013234)

#CS1506 (SE-6) \$10.00

INTERNATIONAL magnetos and distributors. Used on J4 Magneto and International Battery Distributors. (OEM #'s 353-172-R91)

#CS1600 (SE-IH-2) \$6.00



INTERNATIONAL magneto. Used on H-4 Magneto. (OEM # 353-171-R91)

#CS1601 (IH-3) \$6.00

MERCURY (KIEKHAFER) Used on MERCURY outboard 1957-1969. (OEM #'s 393-1504A5,A6, 393-1326A3)

#CS1750 (SE-10) \$12.00

REPCO (PHELON) magneto Used on MERCURY outboard 1953-1969 and LAUSON, TECUMSEH, REMINGTON-MALL, WRIGHT and others. (OEM #'s FG2197, B; FG1835,B,C; FG2645; FG6230; FG6270; FG2400,B; FG6450; 30547; & 398-2202)

#CS1804 (SE-45) \$7.00

REPCO (PHELON) magneto Used on CLINTON small engine. (OEM #'s FG3560 & 5735)

#CS1807 (SE-59) \$7.00

OUTBOARD MARINE LAWNBOY engines. (OEM #'s 677254)

#CS2001 (SE-36) \$6.00

WICO unknown details of application

OEM #5112 \$6.00



WICO Used on KOHLER, WISCONSIN and others as well as the following magnetos: XH, XHD, XHG, XV, XVD and XVE. (OEM#'s X6942 & X5996)

#CS2201 (SE-52) \$11.00

WICO Used on PIONEER Models RA, RB6, RC6, 200, 600, A, 610, 650, 6-20 and some POULAN & REMINGTON-MALL. (OEM no. X11247)

#CS2211 \$12.00

## **ELECTRICAL IGNITION, CHARGING, STARTING, LIGHTING, ETC. IGNITION CONDENSORS - NON AUTOMOTIVE AND SMALL ENGINE**

FAIRBANKS-MORSE magnetoes FMJ, FMX, and FMZ	#FM200 (SE-317)	\$6.00
INTERNATIONAL magneto J4	#IH200 (IH-20)	\$6.00
INTERNATIONAL magneto F4, F6, and H4	#IH201 (IH-21)	\$8.00
WICO XH and XGH models except heavy duty	#WI200 (SE-359)	\$10.00
WICO XB battery distributor	#WI201 (SE-340)	\$9.00
WICO A, AH, C, J, and JEM magnetoes	#WI208	\$10.00
WICO	#X2595	\$10.00
WICO	#X7228	\$10.00
PHELON	#PH201	\$0.00
	#OE200 (S13/10S/SE-356)	\$4.00

## **ELECTRICAL IGNITION, CHARGING, STARTING, LIGHTING, ETC. IGNITION ROTORS - NON AUTOMOTIVE AND SMALL ENGINE**

INTERNATIONAL Used with IH350 and IH 352 distributor caps	#IH300 (IH-40)	\$5.00
INTERNATIONAL Used with IH351 distributor cap on the H4 magneto	#IH301 (IH-45)	\$7.00
WICO used with WI350 cap	#WI300 (SE-391)	\$7.00
WICO used with WI301 cap	#WI301 (SE-392)	\$7.00
	#WI216 (SE-341)	\$7.00
Unknown Application	Echlin #7-01031	\$7.00
	#7-01318 (135-026-000)	\$7.00
	#7-01400	\$7.00
	#7-01401	\$7.00

## **ELECTRICAL IGNITION, CHARGING, STARTING, LIGHTING, ETC. IGNITION DISTRIBUTOR CAPS - NON AUTOMOTIVE AND SMALL ENGINE**

INTERNATIONAL 4 cyl. Used on the 4 cyl battery distributor and the J4 magneto	#IH350 (IH-60)	\$13.00
INTERNATIONAL 4 cyl. Used on the H4 magneto	#IH351 (IH-67)	\$10.00
INTERNATIONAL 6 cyl.Used on the 6 cyl. battery distributor	#IH352 (IH-61)	\$12.00
WICO 4 cyl. used with WI301 rotor on many magnetoes	#WI351 (SE-458)	\$45.00



# **ELECTRICAL IGNITION, CHARGING, STARTING, LIGHTING, ETC. NON-AUTOMOTIVE IGNITION SYSTEM PARTS**

**TUNE UP KITS ARE AMPCO/WELLS BRAND IN BLISTER PACKS  
INCLUDES POINTS CONDENSER and ROTOR**

## **INTERNATIONAL ENGINES**

FARMALL with I.H.C. dist 353-988-R91, 353-943-R91, 353-944-R91, 353-890, 891, 893 R91  
FARMALL A, AV, B, BN, Super A, AV, C, H, HV, M, MV, and Clut  
I.H.C. Super A, Wheel Type 14, 16, 19, 04, 06, OS4, W4, W6, W9, WR9  
POWER UNITS 2A, U264, UD264, UD350, UD505, UD1091 (bat. equip.)  
TRACTORS Super A, A1 (bat. equipped)

#TK201 \$10.00

## **SMALL ENGINE TUNE-UP KITS**

### **AMPCO BRAND**

Kits Contain Points and CONDENSER

BRIGGS and STRATTON 9, 14 and 23 series. (This set is for engines prior to the style with a contact on the end of the condenser. (Contains contacts #CS1202.)

#BR-103 \$7.00

FAIRBANKS-MORSE Magnetos FM-W1A92, FM-W1A93 for LAUSON, POWER PRODUCTS and other small engines.

#FM-109 \$8.00

McCULLOCH Chain Saws Models 3-25, 33, 33B, 4-30, 47 (Contains contacts #CS1700.)

#MC-124 \$8.00

McCULLOCH Chain Saws Model 99

#MC-125 \$8.00

PHELTON MAGNETOS FCA411. Fits CLINTON engines A300, VS300, 500, 650, 700, VS700, 750; 800, VS800, 900, 1100, 1200 and other small engines (Contains contacts #CS1800.)

#PH-134 \$8.00

PHELTON MAGNETOS F109F, F189N, J, K Fits POWER PRODUCTS, SCOTT ATWATER and other small engines (Contains contacts #CS1800.)

#PH-137 \$8.00

PHELTON MAGNETOS F109DM, K, T, F189M, Q, Q-7, R, S, T, T-Z. Fits POWER PRODUCTS and other small engines (Contains contacts #CS1801.)

#PH-138 \$8.00

PHELTON MAGNETOS F109, V; F514A, B, C, E, G, H, J, K, L, R, S. Fits MERCURY Outboards and other small engines (Contains contacts #CS1800.)

#PH-139 \$8.00

PHELTON MAGNETOS F1325A, B, D, D-2. Fits Power Products and other small engines (Contains contacts #CS1800.)

#PH-142 \$8.00

PHELTON MAGNETOS FCA 1290C. Fits CLINTON Engines Series 100, VS100, 2100, A2100, VS200 and other equipment (Contains contacts #CS1801.)

#PH-155 \$8.00

PHELTON MAGNETOS For CLINTON Engines Series A200, AVS200, AVS200-1000, VS200-1000, 200-1000, A400, AVS400, 400-1000, VS400-1000, VS400-2000, D700-2000, D900-2000, VS900, VS1100; 1200-2000 (Contains contacts #CS1801.)

#PH-158 \$8.00

WICO MAGNETOS FW2221-22; 2270; 2316 B-C, FW2320, 2427, 2429. Fits LAUSON Engines

#WI-192 \$8.00

WICO MAGNETOS FW2447-48, 2456-57, 2466 B, FW2467, 2471, B; FW2476, 2489. Fits LAUSON Engines, WEST BEND Chain saws and many other small engines. Engines (Contains contacts #CS2207.)

#WI-193 \$8.00

ORDER FORM

COLLECTOR'S AUTO SUPPLY

6727 Thorne Rd, Peachland B.C. CANADA V0H 1H9

Or: P.O Box 2076 Oroville Washington U.S.A. 98844

PHONE: 1-250-767-1974 FAX: 1-250-767-3340

E-MAIL: Jim@CollectorsAutoSupply.com

WEB: CollectorsAutoSupply.com

NAME: \_\_\_\_\_

STREET: \_\_\_\_\_

CITY: \_\_\_\_\_

ZIP/CODE: \_\_\_\_\_

PHONE: \_\_\_\_\_

FAX/E-MAIL: \_\_\_\_\_

YEAR/MAKE/MODEL: \_\_\_\_\_

DISTRIBUTOR MAKE & NUMBER: \_\_\_\_\_

(Helps ensure your order is correct.)

ITEM DESCRIPTION	ITEM #	QTY.	PRICE	TOTAL
_____	_____	_____	_____	_____
_____	_____	_____	_____	_____
_____	_____	_____	_____	_____
_____	_____	_____	_____	_____
_____	_____	_____	_____	_____
_____	_____	_____	_____	_____
_____	_____	_____	_____	_____
_____	_____	_____	_____	_____

C.O.D., VISA/MC Or CHEQUE TO: COLLECTORS AUTO SUPPLY SUB TOTAL: \_\_\_\_\_

VISA/MC #: \_\_\_\_\_

EXPIRY DATE: \_\_\_\_\_

SIGNATURE: \_\_\_\_\_

DOMESTIC SHIPPING: \$7.00

TOTAL: \_\_\_\_\_